

Sounding apparatus with inversion switch and start-stop system

Manual

Main functions

The sounding devices (110330 (10 m, electrode \varnothing 14 mm) and 110332 (30 m, electrode \varnothing 14 mm) are equipped with an inversion switch and a two-pole connection with banana plugs. With the aid of a separately available cable (art. no.: 12252610 for the peristaltic pump 1225/1226 and art. no 123506 for the peristaltic pump Advanced 1235) this sounding device can be connected to a peristaltic pump with a start-stop system.

With the switch in the *WATER* position this sounding device works like any other. A continuous tone and light signal indicate when the sensor is in the water.

If the switch is pushed into the *AIR + SW(itch)* position the signal is changed over. If the sensor is in the air, an interrupted waiting tone sounds. The light also flashes on and off. If the sensor is submerged under water again this waiting tone stops. The cable connection is also activated using the switch function.

Standards and directives

This sounding device is specially designed for use in the preliminary pumping (purging) of monitoring wells in accordance with:

- The Dutch standard NEN 5744-2011 for the sampling of groundwater.
- The American standard EPA504-S95-504 low flow (minimal drawdown) groundwater sampling procedure.
- The international directive ISO 5667-11: 2009 sampling of groundwater (micro-purging section).

The purpose of this method of preliminary pumping is to limit the drop in water level such that the inflowing water draws many fewer soil particles into the filter pipe, resulting in much more accurate analyses. In the Netherlands the maximum drop is 50 cm. In the US it is 10-30 cm. The ISO standard does not define a drop.

Application

After opening the monitoring well, first determine the undisturbed water level in the monitoring well with the sounding device in the *WATER* position. Make a note of this level. Then push the inversion switch into the *AIR* position (signal stops) and allow the sensor to fall a maximum of 50 cm deeper into the water. Wedge the cable. Then fit the sampling hose (possibly with the pump beneath it) halfway down the filter section of the monitoring well. By the use of weights (art. no.: 122090) you can also get the hose down to a great depth at the bottom of the monitoring well. If you use a peristaltic pump you can insert the hose whilst the pump is running slowly (prevention of buoyancy). Usually you should allow the hose to sink right down. Then first pump the sediment at the bottom away. Do not turn the hose round as this will cause too much turbidity. Then lift the hose by 50 cm (for a filter length of one metre) and clamp the hose at this depth above ground.

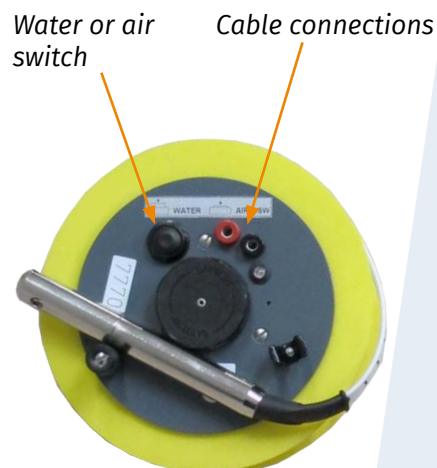

If the water level falls due to pumping, the device will begin to emit an interrupted signal when the water level has fallen by 50 cm. This is a sign that the pump must be turned down to a slower rate than the maximum 500 ml/min. Set a slower flow rate. The lowest flow rate that you have to use is 100 ml/minute (NEN 5744:2011). If the water level still falls, the monitoring well is not running properly. Make a note of this in the report. Consult the standard and any protocols to ascertain how to proceed.



When to use

The inversion switch can be used with any pump. However, if you have a peristaltic pump with a start-stop system (Eijkelkamp peristaltic pumps 1225 (green) and 1226 (blue) from after mid-2011 or renovated) then connect cable 12252601 between the sounding device and the pump. When you have a peristaltic pump 12 VDC Advanced 1235 please use the cable 123506. The pump then stops automatically when the sensor no longer senses water and starts back up automatically after a fixed waiting time. This means that, even without your presence and regardless of the speed set, the water level does not fall below 50 cm. You can then perform preliminary pumping on several monitoring wells of a project at the same time according to the standard.



General instruction

Power supply: 4 Babycells 1.5 Vdc separated in two battery-boxes. Use leak proof batteries only ! Signal lamp: 5 V, 0.15 A. Operates in water with a specific conductivity (salt content) between 50 microS/cm till 180 milliS/cm. Accuracy < 1 cm with tape length 100 m.

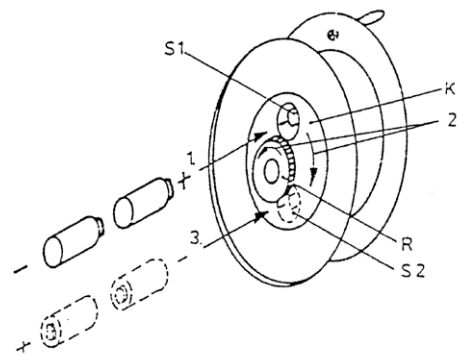

1. Insert two batteries into the open battery box (S1) according to the red mark. Consider polarity.
2. Twist black knurl (R) and turn contactdisk (K) until the second battery box (S2) is open.
3. Insert two batteries more. Consider the red mark inside the battery box and the polarity.
4. Close the second battery box (S2) while twisting the contact-disk (K) until the round hole locks with the black elevation (E). Consider the marking.
5. Fasten black knurl (R). The instrument is ready for use now. When the electrode is touching the water level the signal lamp is gleaming. If a buzzer is installed additionally, you will hear an acoustic signal, too.
6. Please clean the electrode (C) from time to time with smooth emery paper after screwing off the protection cover.
7. Exchange of signal lamp: Screw off orange coloured protection cover. Exchange signal lamp, screw on cover again.

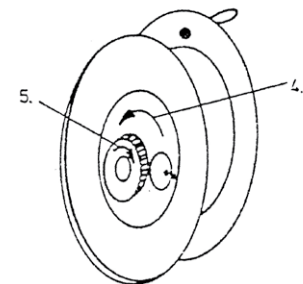

Please handle the instrument carefully during operation and transport. If the instrument is not used over a long period, please take out the batteries.

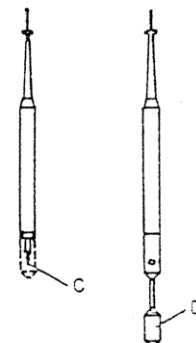

Nothing from this document may be copied and/or made public by means of printing, photocopy, microfilm or in any other way whatsoever without the prior written permission of the publisher. Technical data can change without prior notification. Royal Eijkelkamp is not responsible/liable for damage/personal injury due to the use or misuse of this product. Royal Eijkelkamp is pleased to receive your feedback and comments about its products and this user manual.