

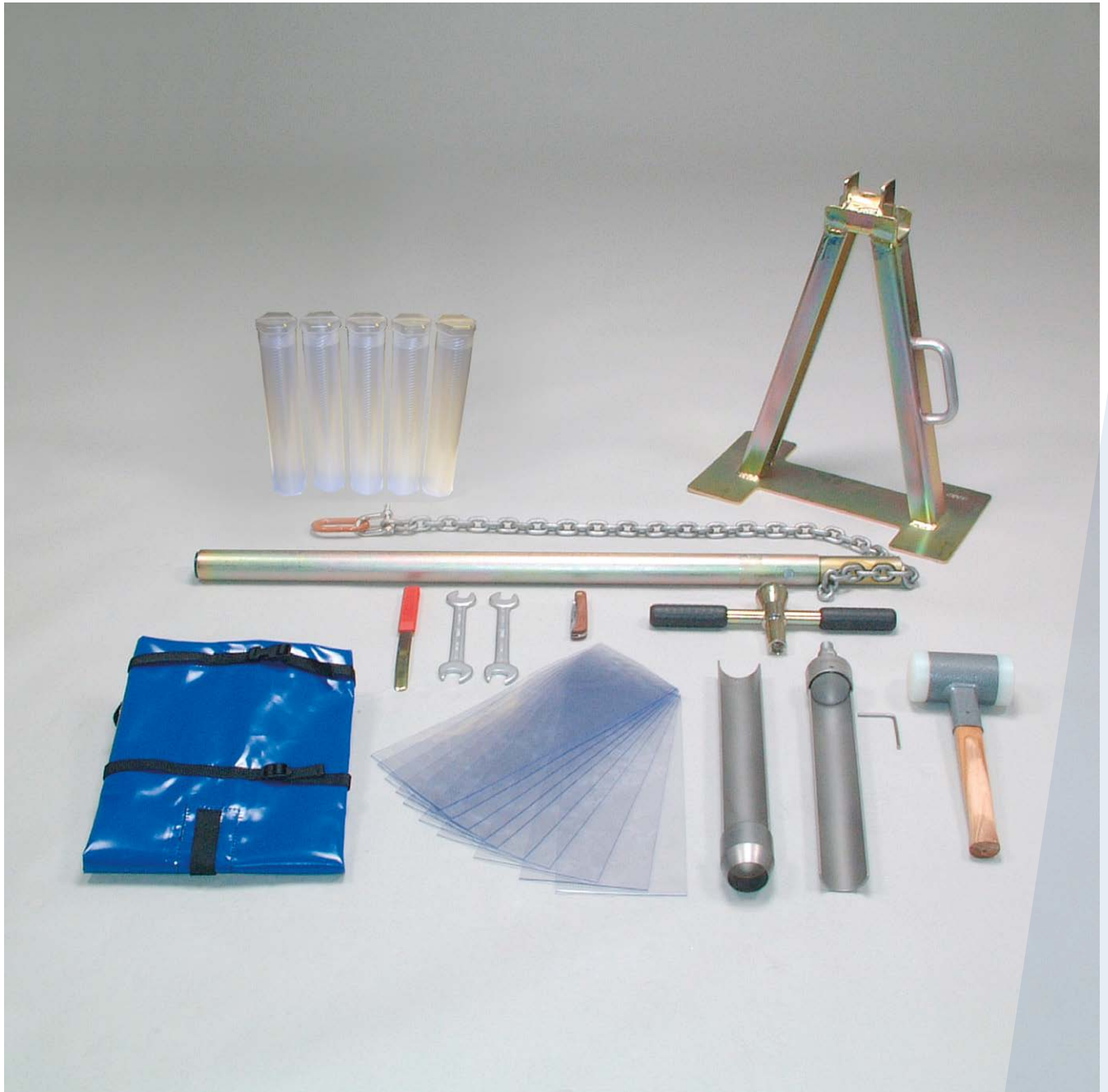

# Split tube sampler

## Manual



*Meet the difference*

## Contents

On these operating instructions.....	3
1. Description .....	3
2. Technical specifications .....	3
3. Safety .....	4
4. Use .....	4
5. Applications .....	5
6. Maintenance.....	5

Nothing in this publication may be reproduced and/or made public by means of print, photocopy, microfilm or any other means without previous written permission from Royal Eijkelkamp. Technical data can be amended without prior notification.

Royal Eijkelkamp is not responsible for (personal) damage due to (improper) use of the product.

Royal Eijkelkamp is interested in your reactions and remarks about its products and operating instructions.

## On these operating instructions



If the text follows a mark (as shown on the left), this means that an important instruction follows.



If the text follows a mark (as shown on the left), this means that an important warning follows relating to danger to the user or damage to the apparatus. The user is always responsible for its own personal protection.

Text

**Italic indicated text indicates that the text concerned appears in writing on the display (or must be typed).**

## 1. Description

The split tube sampler is a piece of equipment suitable chiefly for rapid undisturbed sample taking from surface layers. It is particularly suitable for use in research into root systems, fertilising and soil biology tests.

Because the two sections of the sampler can be taken apart easily once the locking pin (3) has been removed and the sample is held in the sample liner, undisturbed sampling is made possible. The sampler is joined to the top section that has the beating head (4) by means of a conical thread.

The sampler can be extracted from the ground with the use of a lifting jack (7) and lever with chain (8). The sample which is enclosed in the liner can be kept stored in a closed sample tube (5) with a cap at one end (6).

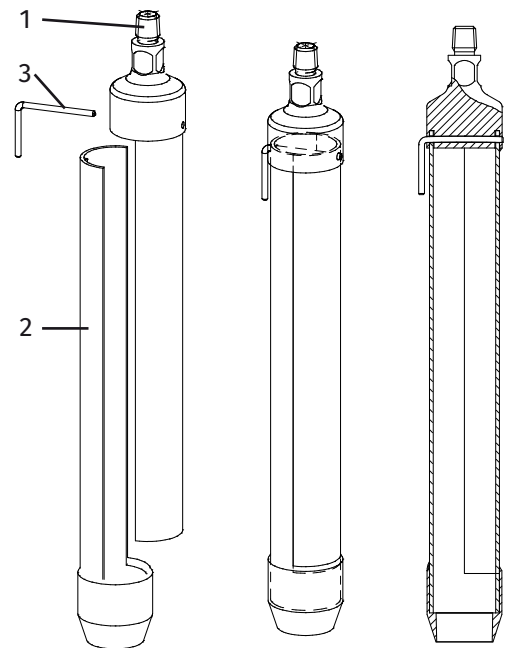

## 2. Technical specifications

Part	Characteristics
Split tube sampler	Stainless steel, operational length 40 cm,
Cutting head	Ø 53 mm (inside diameter)
Lifting jack	Ø 48 mm (inside diameter)
Lever with chain	10,3 kg. 46x25x55 cm.
Chain	9,7 kg. 110 cm. Max. load 1000 N
Sample tube, incl. cap	100 cm
Sample liner	length 40 cm, for samples Ø 53 mm
Carrying bag	Transparent soft PVC
	length 40 cm, inside Ø 50 mm
	77x20x20 cm

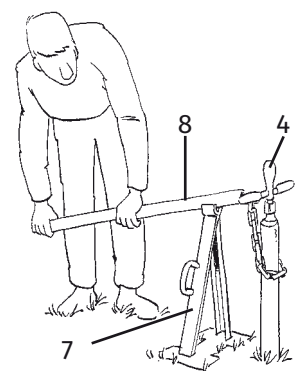
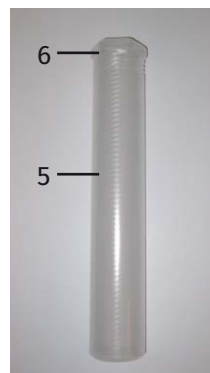

### 3. Safety



Before commencing drilling check whether there are (power) cables or pipes in the ground (check with Klic, the Cable and Pipe Information Centre). It is advisable to use the optional utility probe to check the area of soil in safety. If cables, etc. are found, find another spot to drill.



During drilling always keep hold of the auger by its synthetic grip. This grip provides powerful insulation should a power cable accidentally be disturbed.



Once the drilling is completed refill the borehole properly with the loose drillings or with special bentonite plugs. This is to prevent people or animals from stepping into the hole and injuring themselves. It also helps restore impermeable soil layers.



Always take great care during thundery conditions. In the open field the risk of a lightning strike is considerably higher.



Always use an impact absorbing hammer, if hammer force is required. This is safer and avoids damage to the auger. Never use a (metal) hammer that is not impact absorbing. Such a hammer may damage the auger and may cause injury as it rebounds.

### 4. Use

1. Carefully plan in advance where you intend to drill and to what depth.



Before commencing drilling check whether there are (power) cables, or pipes in the ground (check with Klic, the Cable and Pipe Information Centre). It is advisable to use the optional utility probe to check the area of soil in safety. If cables, etc. are found, find another spot to drill.



Do not use the sampler in too hard soils. The sampler may break.



During drilling always keep hold of the auger by its synthetic grip. This grip provides powerful insulation should a power cable accidentally be disturbed.

2. Remove the locking pin (3) and free the two halves.
3. Roll some sampler lining into the removable section, see the figure on the far right – press the two halves back together and secure them with the locking pin (3).
4. Screw the top piece (4) with the drive head onto the sampler (1). To tighten the connection use the open-ended spanner provided.



5. After locating the intended spot, press the auger vertically into the ground to the desired depth. If necessary an impact absorbing hammer can be used to drive the auger into the ground.



Always use an impact absorbing hammer, if hammer force is required. This is safer and avoids damage to the auger. Never use a (metal) hammer that is not impact absorbing. Such a hammer may damage the auger and may cause injury as it rebounds.

6. Position the lifting jack (7) close to the auger (see the figure on Page 2).
7. Attach the lever into the pivot point of the lifting jack with the use of a capped nut.
8. Wrap the chain round the top of the sampler and pull one end of it through the large chain link.
9. Attach the chain to the lever by placing it in the opening. The chain should be fairly taut.
10. Raise the sampler by pressing down on the end of the lever (see the figure on the right).

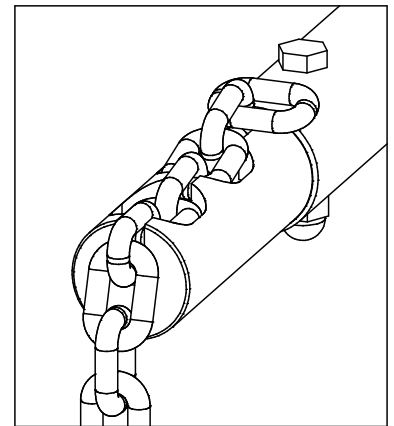

**The maximum load for the lever is 1000 N.  
This gives a tensile strength of 4500 N.**

11. Raise the end of the lever to allow the chain to drop down further over the sampler. Repeat steps 10 and 11 until the sampler has been pulled out.
12. Remove the locking pin (3) and separate the two halves.
13. Carefully remove the sample which may be wrapped in liner and place it in a sample tube. Close the sample tube firmly (see the figure on the right).

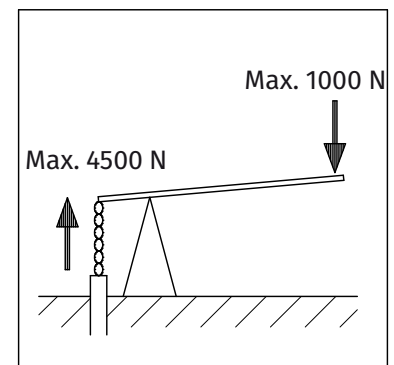

## 5. Applications

The split tube sampler is used among other things for:

- Root system research.
- Accurate appraisal (samples for profile description).
- Fertilising or chemical research and soil biology tests.



## 6. Maintenance

- The body of the auger does not need sharpening. Continued use will keep making it sharper.
- Keep materials clean by rinsing off any accumulated dirt. Keep in a dry place.